

## GR-15E005DG: Enhancement Mode Power Transistor

### Description

GR-15E005DG is an enhancement mode GaN on Silicon power transistor. 15E005DG provides, high current and high operating speed which is suitable for DC to DC power supply applications.

### Key Specifications

Part Number	GR-15E005DG
$V_{DSS}$ , min.	150V
$I_{DS}$ , Pulse (25°C, TPULSE = 300μs)	155A
$R_{DS(ON)}$ , typ. @ $V_{GS}=5V$	5.4mΩ
$Q_G$ , typ.	9.4nC

### Features

- 150V enhancement mode power transistor
- High operating frequency
- $R_{DS(on)}$  = Typ. 5.4mΩ
- Dual-side cooled package
- HS compliant

### Applications

- Switch Mode Power Supplies (SMPS)
- DC-DC Converters
- Fast Battery Charging
- Appliance Motor Drives

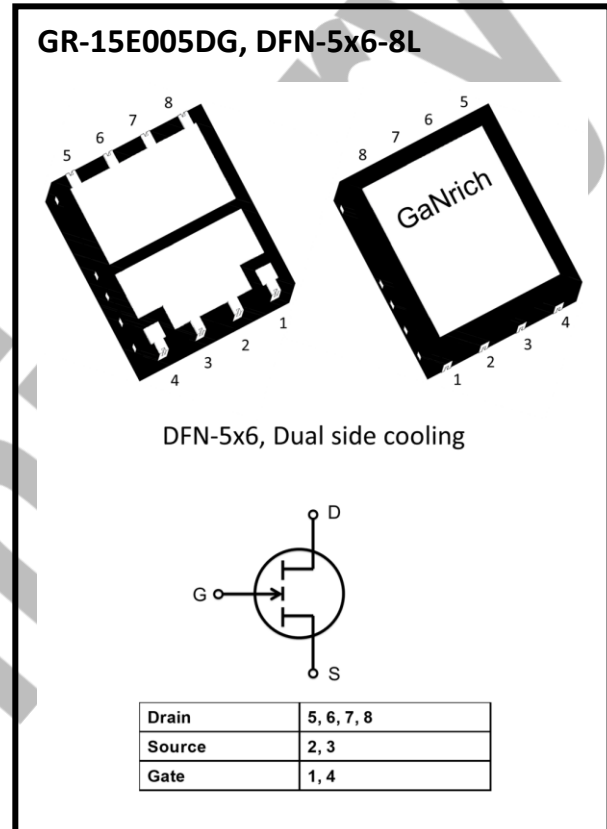

### 1. Electrical Characteristics

➤ **Table 1 Absolute maximum ratings**

Symbol	Parameter	Value	Unit
$V_{DSS}$	Drain-source voltage	150	V
$V_{(TR)DSS}$	Transient drain to source voltage <sup>a</sup>	180	V
$V_{GSS}$	Gate- source voltage	-6V ~ +6V	V
$I_D$	Drain current (continuous) at $T_C = 25^\circ\text{C}$ operation	50	A
	Drain current (continuous) at $T_C = 100^\circ\text{C}$ operation	34.5	A
$I_{DM}$	Pulsed drain current (pulse width: 300 $\mu\text{s}$ , $V_{GS}=5\text{V}$ ) <sup>b</sup>	155	A
$T_J$	Operating temperature	-40 to +150	$^\circ\text{C}$
$T_S$	Storage temperature	-40 to +150	$^\circ\text{C}$
MSL	Moisture sensitivity level	MSL3	

- a. In off-state, spike duty cycle  $D < 0.01$ , spike duration  $< 1\mu\text{s}$   
 b. Defined by product design and characterization. Value is not tested to full current in production

➤ **Table 2 Thermal Characteristics**

Symbol	Parameter	Value	Unit
$R_{\theta JC (top)}$	Thermal resistance junction-case <sup>a</sup> , top	0.30	$^\circ\text{C}/\text{W}$
$R_{\theta JC (bottom)}$	Thermal resistance junction-case <sup>a</sup> , bottom	0.45	$^\circ\text{C}/\text{W}$
$R_{\theta JA}$	Thermal resistance junction-ambient <sup>b</sup>	60	$^\circ\text{C}/\text{W}$

- a. Tested in package DFN-5x6.  
 b. Device on 1 layer PCB.

➤ **Table 3 Electrical Characteristics** ( $T_{CASE} = 25\text{ }^{\circ}\text{C}$  unless otherwise stated)

Symbol	Parameter	Conditions	Values			Unit
			min.	typ.	max.	
$BV_{DSS}$	Drain-source voltage	$V_{GS} = 0V, I_D = 100\mu A$	150	-	-	V
$V_{GS(th)}$	Gate threshold voltage	$V_{DS} = V_{GS}, I_D = 15mA$	0.8	1.1	1.5	V
$R_{DS(on)}$	Drain-source on-resistance	$V_{GS} = 5V, I_D = 15A$	-	5.4	7.4	$m\Omega$
$I_{DSS}$	Drain-source leakage current	$V_{DS} = 120V, V_{GS} = 0V$	-	3.0	240	$\mu A$
$I_{GSS}$	Gate-to-Source Forward Leakage current	$V_{GS} = +5V$	-	0.05	10.0	mA
	Gate-to-Source Forward Leakage current	$V_{GS} = +5V, T_J = 125^{\circ}\text{C}$	-	0.60	18.0	mA
	Gate-to-Source Reverse Leakage current	$V_{GS} = -4V$	-	0.035	1.05	mA
$C_{ISS}$	Input capacitance	$V_{DS} = 75V, V_{GS} = 0V$	-	1390	-	pF
$C_{OSS}$	Output capacitance		-	334	-	
$C_{RSS}$	Reverse transfer capacitance		-	2.5	-	
$Q_G$	Gate charge	$V_{DS} = 75V, V_{GS} = 5V, I_D = 15A$	-	9.4	-	nC
$Q_{GS}$	Gate-source charge	$V_{DS} = 75V, I_D = 15A$	-	3.1	-	
$Q_{GD}$	Gate-drain charge		-	0.8	-	
$Q_{OSS}$	Output charge	$V_{DS} = 75V, V_{GS} = 0V$	-	41.8	-	
$Q_{RR}$	Source-Drain Recovery Charge	-	-	0	-	

### 1. Package Outline Dimensions (DFN-5x6-8L)

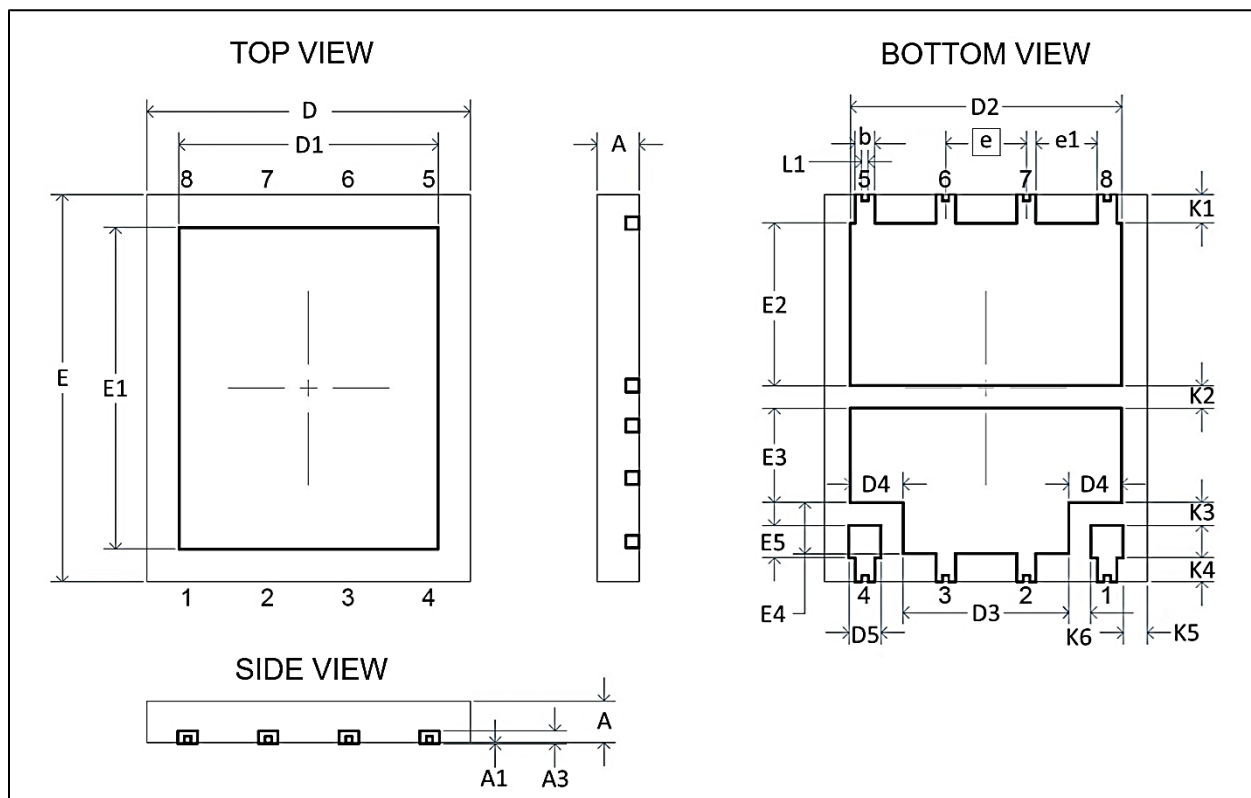

➤ Table 4 Dimension of GR-DFN-5x6-8L

SYMBOL	DIMENSION (MM)			SYMBOL	DIMENSION (IN MM)		
	MIN.	NOM.	MAX.		MIN.	NOM.	MAX.
A	0.60	0.65	0.70	E1	4.977 REF		
A1	--	0.02	0.05	E2	2.42	2.52	2.62
A3	0.203 REF			E3	1.36	1.46	1.56
D	4.90	5.00	5.10	E4	0.69	0.79	0.89
E	5.90	6.00	6.10	E5	0.40	0.50	0.60
e	1.25 BSC			K1	0.34	0.44	0.54
e1	0.85	0.95	1.05	K2	0.25	0.35	0.45
b	0.20	0.30	0.40	K3	0.257	0.357	0.457
D1	4.018 REF			K4	0.273	0.373	0.473
D2	4.10	4.20	4.30	K5	0.275	0.375	0.475
D3	2.468	2.568	2.668	K6	0.241	0.341	0.441
D4	0.716	0.816	0.916	L1	0.05	0.10	0.20
D5	0.40	0.50	0.60	-	-	-	-

## 2. Change Log

Version	Date	Description
0.1	March 28, 2025	Initial version
0.2	April 16, 2026	Electrical characteristics revised

- **Note:** GaNrich semiconductor reserves the right to revise products and/or specifications without notice.