

GR-15E007DJ: E-mode GaN Power Transistor

Description

GR-15E007DJ is an enhancement mode GaN on Silicon power transistor. 15E007DJ provides high current and high operating speed which is suitable for DC to DC power supply applications.

Key Specifications

Part Number	GR-15E007DJ
V _{DSS} , min.	150V
I _{DS} , Pulse (25°C, TPULSE = 300 μs)	109A
R _{DS(ON)} , typ. @V _{gs} =6V	7.3mΩ
Q _G , typ.	7.1nC

Features

- 150 V enhancement mode power transistor
- High operating frequency
- R_{DS(on)} = Typ. 7.3mΩ
- RoHS compliant
- Zero QRR.

Applications

- Switch Mode Power Supplies (SMPS)
- DC-DC Converters
- Fast Battery Charging
- Appliance Motor Drives

GR-15E007DJ, DFN-5x6-8L

Drain	5, 6, 7, 8
Gate	4
Source	1, 2, 3

Table of Contents

	Description	1
	Key Specifications	1
	Features.	1
	Applications	1
	Table of Contents	2
1	Electrical Characteristics and Parameters	3
2	Typical Characteristic Curves	5
3	Package Outline Dimensions	7
4	Recommended PCB Soldering footprint	8
5	Tape and Reel Information	9
6	Change Log.	10

1. Electrical Characteristics

➤ **Table 1 Absolute maximum ratings**

Symbol	Parameter	Value	Unit
V_{DSS}	Drain-source voltage	150	V
$V_{(TR)DSS}$	Transient drain to source voltage ^a	180	V
V_{GSS}	Gate- source voltage	-4V ~ +6V	V
I_D	Drain current (continuous) at $T_C = 25^\circ\text{C}$ operation	35	A
	Drain current (continuous) at $T_C = 100^\circ\text{C}$ operation	24	A
$I_{D,Pulse}$	Pulsed drain current (pulse width: 300 μs , $V_{gs}=5\text{V}$) ^b	109	A
T_J	Operating temperature	-40 to +150	$^\circ\text{C}$
T_S	Storage temperature	-40 to +150	$^\circ\text{C}$
MSL	Moisture sensitivity level	MSL3	

a. In off-state, spike duty cycle $D < 0.01$, spike duration $< 1\mu\text{s}$

b. Defined by product design and characterization. Value is not tested to full current in production

➤ **Table 2 Thermal Characteristics**

Symbol	Parameter	Value	Unit
$R_{\theta JC_Top}$	Thermal resistance junction-case, Top	0.65	$^\circ\text{C}/\text{W}$
$R_{\theta JC_Bot}$	Thermal resistance junction-case, Bottom	0.50	$^\circ\text{C}/\text{W}$
$R_{\theta JA}$	Thermal resistance junction-ambient	60	$^\circ\text{C}/\text{W}$

a. Tested in package DFN-5x6.

➤ **Table 3 Electrical Characteristics** ($T_{CASE} = 25\text{ }^{\circ}\text{C}$ unless otherwise stated)

Symbol	Parameter	Conditions	Values			Unit
			min.	typ.	max.	
V_{DSS}	Drain-source voltage	$V_{GS} = 0V, I_D = 250\mu A$	150	-	-	V
$V_{GS(th)}$	Gate threshold voltage	$V_{DS} = V_{GS}, I_D = 1mA$	0.8	1.1	1.5	V
$R_{DS(on)}$	Drain-source on-resistance	$V_{GS} = 6V, I_D = 20A$	-	7.3	9.5	m Ω
I_{DSS}	Drain-source leakage current	$V_{DS} = 120V, V_{GS} = 0V$	-	5	100	μA
I_{GSS}	Gate-to-Source Forward Leakage current	$V_{GS} = +5V, T_J = 25^{\circ}\text{C}$	-	36	650	μA
	Gate-to-Source Forward Leakage current	$V_{GS} = +5V, T_J = 125^{\circ}\text{C}$	-	900	4200	μA
	Gate-to-Source Reverse Leakage current	$V_{GS} = -4V, T_J = 25^{\circ}\text{C}$	-	24	960	μA
C_{ISS}	Input capacitance	$V_{DS} = 75V, V_{GS} = 0V$	-	608	-	pF
C_{OSS}	Output capacitance		-	294	-	
C_{RSS}	Reverse transfer capacitance		-	10.5	-	
Q_G	Gate charge	$V_{DS} = 75V, V_{GS} = 5V, I_D = 20A$	-	7.1	-	nC
Q_{GS}	Gate-source charge	$V_{DS} = 75V, I_D = 20A$	-	2.6	-	
Q_{GD}	Gate-drain charge		-	1.5	-	
Q_{OSS}	Output charge	$V_{DS} = 75V, V_{GS} = 0V$	-	37.8	-	
Q_{RR}	Source-Drain Recovery Charge	-	-	0	-	

2. Typical Characteristic Curves

Fig 1. On-Region Characteristics

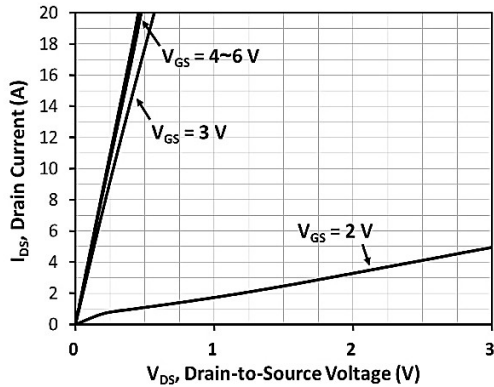

Fig 2. On-Resistance vs Drain Current and Temperature

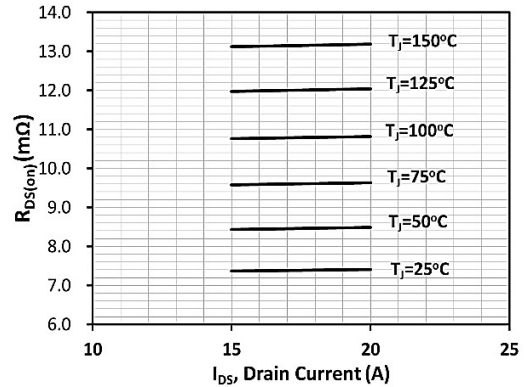

Fig 3. On-Resistance with Drain Current

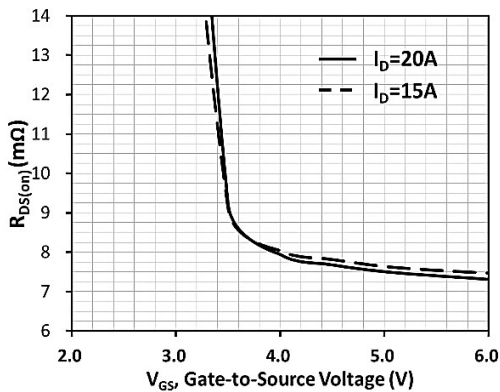

Fig 4. On-Resistance Variation with Temperature

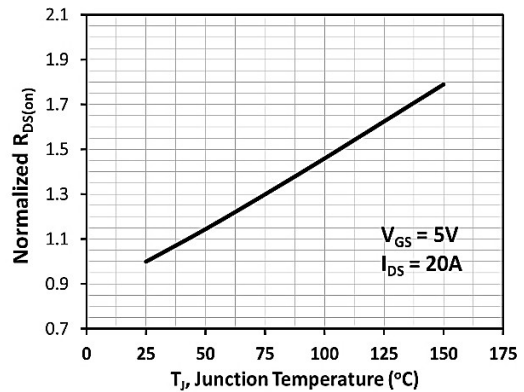

Fig 5. Threshold Voltage with Temperature

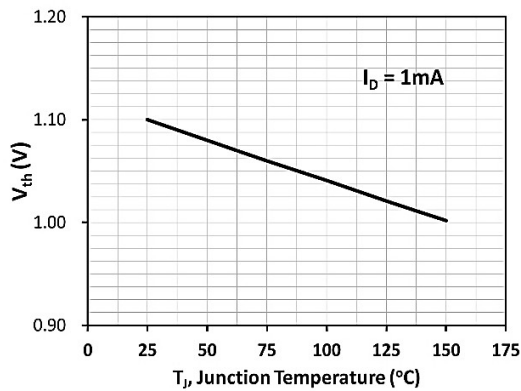

Fig 6. Capacitance Characteristics

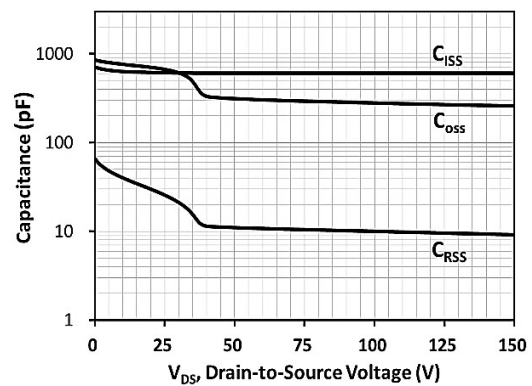

Fig 7. Gate Charge Characteristics, Qg

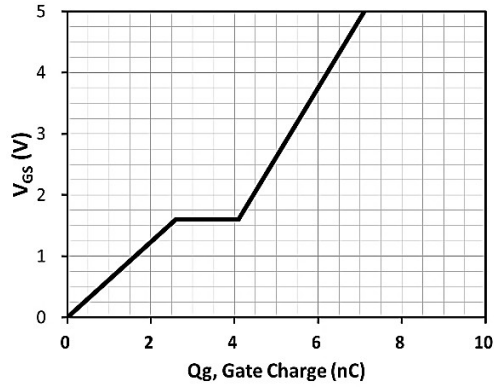

Fig 8. Capacitance Characteristics, Qoss

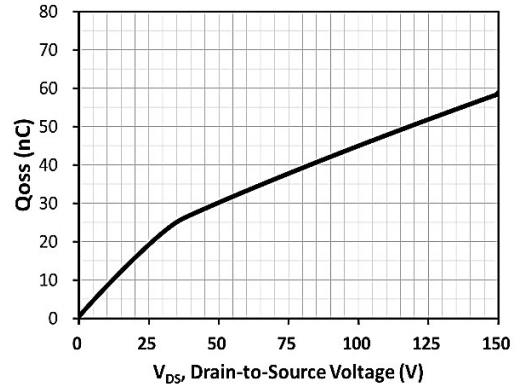
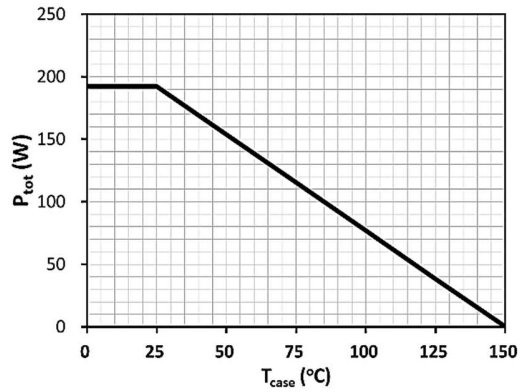
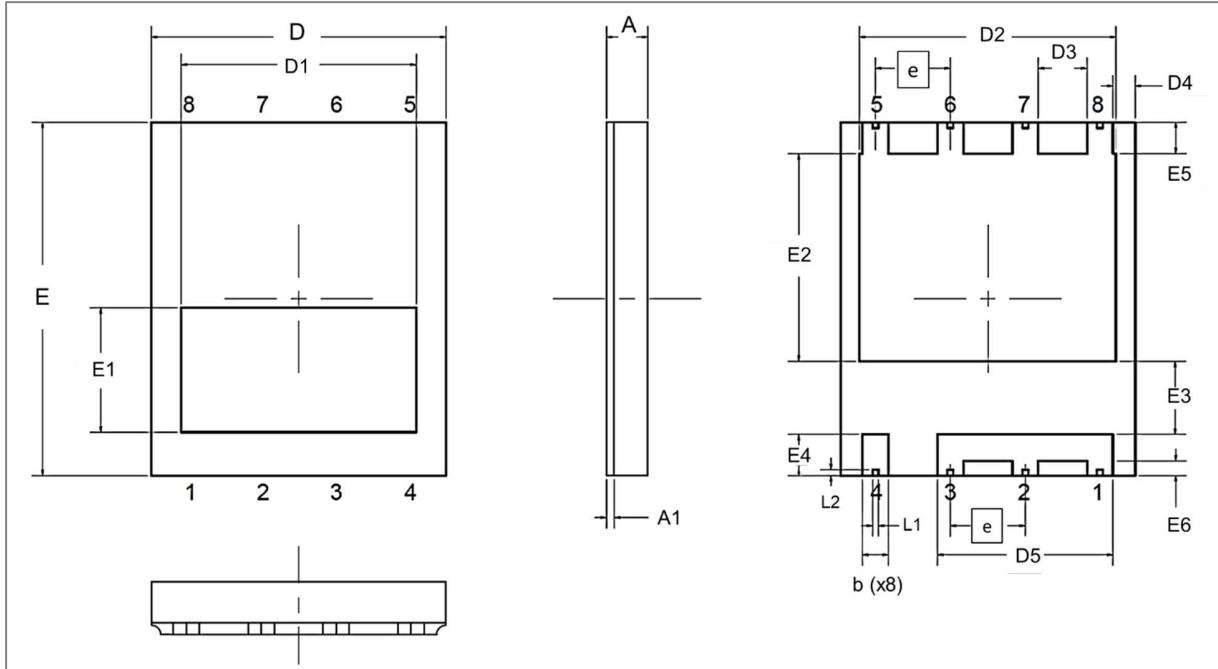

Fig 9. Power Dissipation Derating, Ptot



3. Package Outline Dimensions



➤ Table 4 Dimension of GR-DFN-5x6-8L

SYMBOL	DIMENSION (IN MM)			SYMBOL	DIMENSION (IN MM)		
	MIN.	NOM.	MAX.		MIN.	NOM.	MAX.
A	---	---	0.70	D5	2.88	2.98	3.08
A1	0.13			E1	2.112 REF		
A2	0.42	0.45	0.48	E2	3.43	3.53	3.63
D	4.90	5.00	5.10	E3	1.14	1.24	1.34
E	2.90	6.00	3.10	E4	0.60	0.70	0.80
e	1.270 BSC			E5	0.43	0.53	0.63
b	0.34	0.44	0.54	E6	0.15	0.25	0.35
D1	3.994 REF			L1	0.05	0.10	0.20
D2	4.25	4.35	4.45	L2	0.05	0.10	0.20
D3	0.73	0.83	0.93				
D4	0.275	0.375	0.475				

4. Recommended PCB footprint

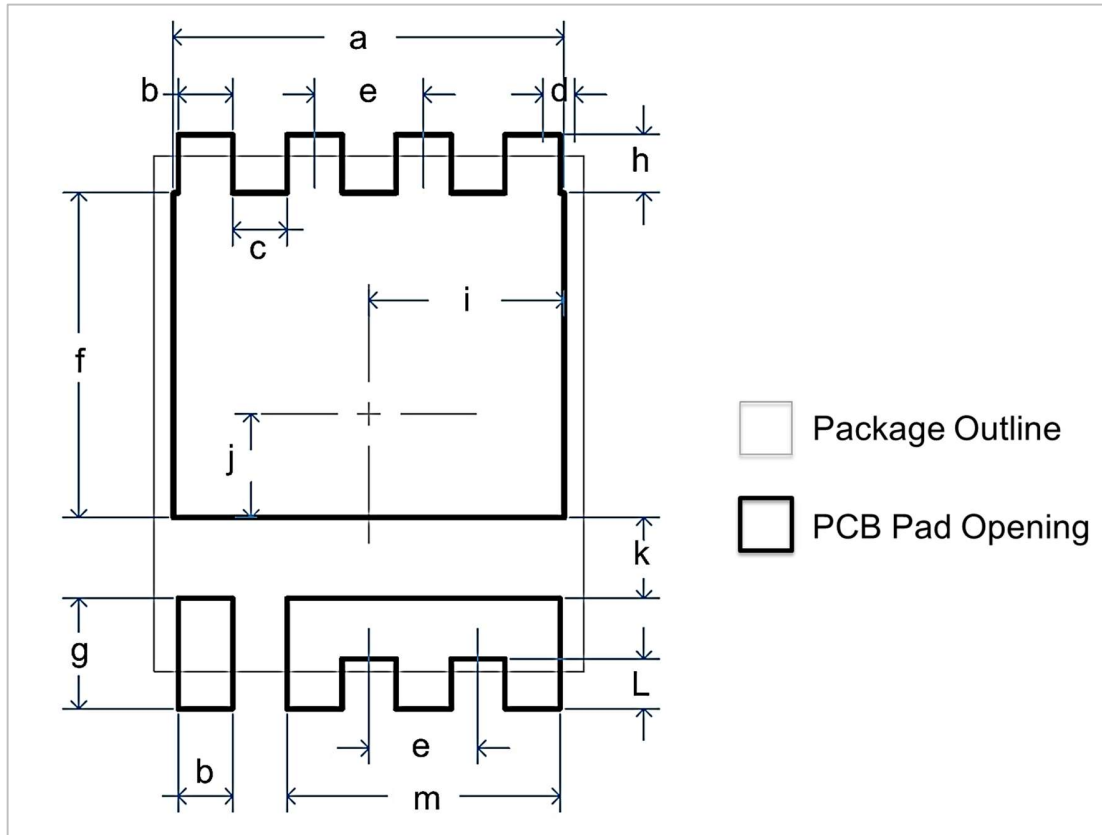

➤ Table 5 PCB Footprint Dimension

SYMBOL	DIMENSION	SYMBOL	DIMENSION
a	4.550	h	0.680
b	0.640	i	2.275
c	0.630	j	1.210
d	0.375	k	0.940
e	1.270	L	0.580
f	3.780	m	3.180
g	1.280	-	-

Notes:
 (1) All dimensions are in mm.
 (2) Drawing is not to Scale.

5. Tape & Reel Information

13" Reel, Carrier Tape W=12mm

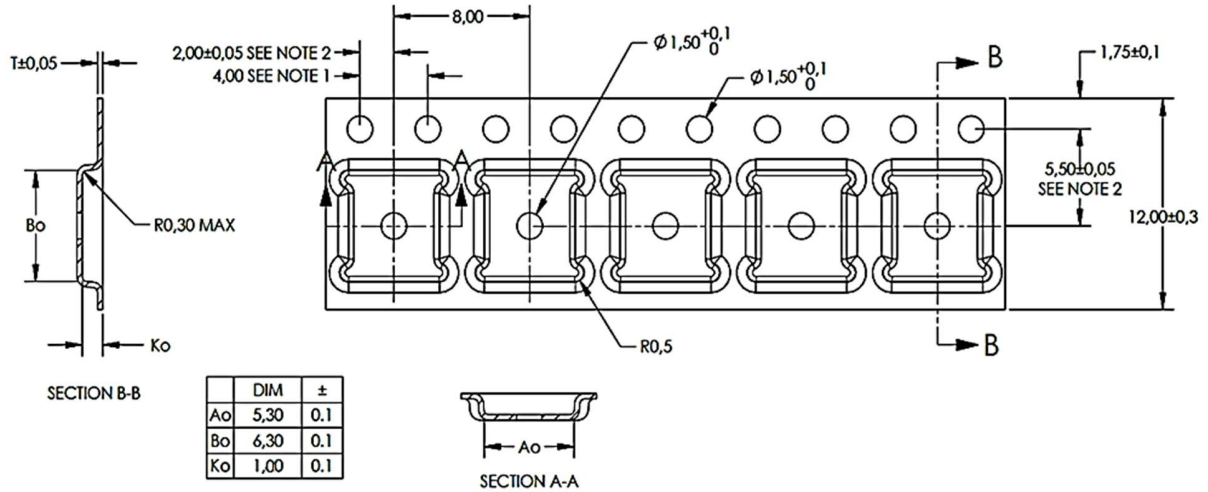

Unit: mm

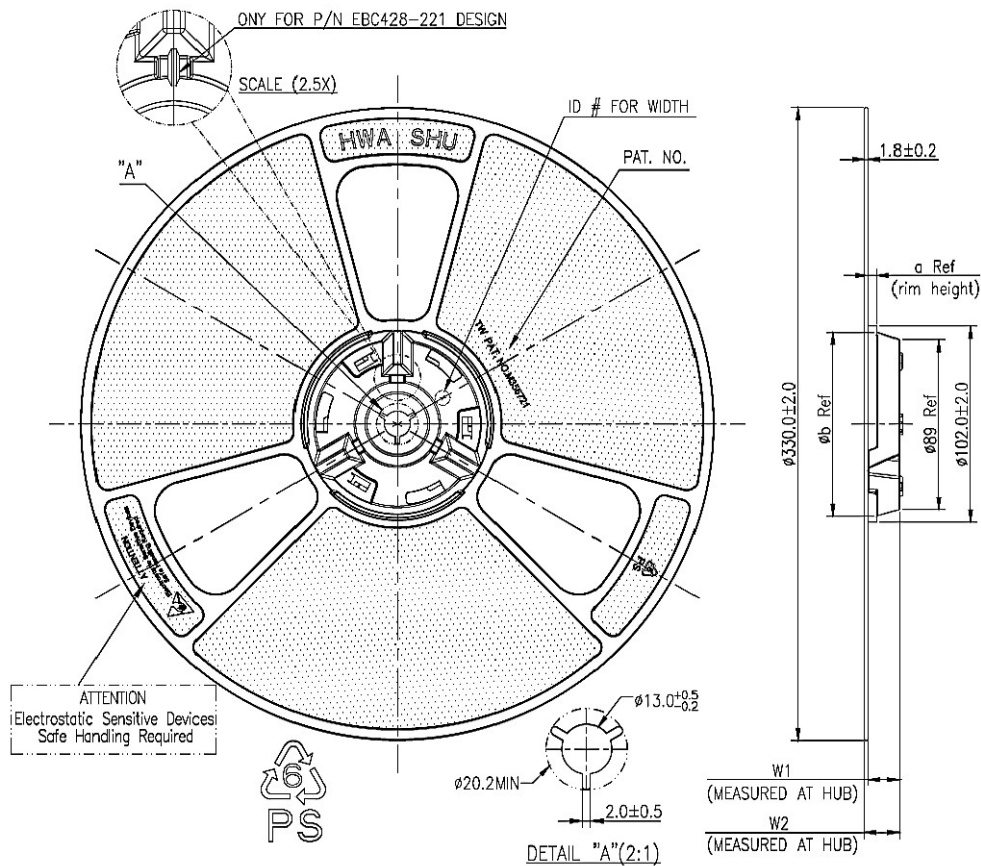

6. Change Log

Version	Date	Description
0.1	March 28, 2025	Initial version
0.2	October 22, 2025	Revised electrical characteristic curves.

- **Note:** GaNrich semiconductor reserves the right to revise products and/or specifications without notice.