

### GR-15E005DJ: E-mode GaN Power Transistor

#### Description

GR-15E005DJ is an enhancement mode GaN on Silicon power transistor. 15E005DJ provides high current and high operating speed which is suitable for DC to DC power supply applications.

#### Key Specifications

Part Number	GR-15E005DJ
V <sub>DSS</sub> , min.	150V
I <sub>DS</sub> , Pulse (25°C, TPULSE = 300 μs)	155A
R <sub>DS(ON)</sub> , typ. @Vgs=6V	5.5mΩ
Q <sub>G</sub> , typ.	9.2nC

#### Features

- 150 V enhancement mode power transistor
- High operating frequency
- R<sub>DS(on)</sub> = Typ. 5.5mΩ
- RoHS compliant
- Zero QRR.

#### Applications

- Switch Mode Power Supplies (SMPS)
- DC-DC Converters
- Fast Battery Charging
- Appliance Motor Drives

**GR-15E005DJ, DFN-5x6-8L**

Drain	5, 6, 7, 8
Gate	4
Source	1, 2, 3

## Table of Contents

	Description . . . . .	1
	Key Specifications . . . . .	1
	Features. . . . .	1
	Applications . . . . .	1
	Table of Contents . . . . .	2
1	Electrical Characteristics and Parameters . . . . .	3
2	Typical Characteristic Curves . . . . .	5
3	Package Outline Dimensions . . . . .	7
4	Recommended PCB Soldering footprint . . . . .	8
5	Tape and Reel Information . . . . .	9
6	Change Log. . . . .	10

### 1. Electrical Characteristics

➤ **Table 1 Absolute maximum ratings**

Symbol	Parameter	Value	Unit
$V_{DSS}$	Drain-source voltage	150	V
$V_{(TR)DSS}$	Transient drain to source voltage <sup>a</sup>	180	V
$V_{GSS}$	Gate- source voltage	-4V ~ +6V	V
$I_D$	Drain current (continuous) at $T_C = 25^\circ\text{C}$ operation	50	A
	Drain current (continuous) at $T_C = 100^\circ\text{C}$ operation	34.5	A
$I_{D,Pulse}$	Pulsed drain current (pulse width: $300\mu\text{s}$ , $V_{gs}=5\text{V}$ ) <sup>b</sup>	155	A
$T_J$	Operating temperature	-40 to +150	$^\circ\text{C}$
$T_S$	Storage temperature	-40 to +150	$^\circ\text{C}$
MSL	Moisture sensitivity level	MSL3	

a. In off-state, spike duty cycle  $D < 0.01$ , spike duration  $< 1\mu\text{s}$

b. Defined by product design and characterization. Value is not tested to full current in production

➤ **Table 2 Thermal Characteristics**

Symbol	Parameter	Value	Unit
$R_{\theta JC\_Top}$	Thermal resistance junction-case, Top	0.65	$^\circ\text{C}/\text{W}$
$R_{\theta JC\_Bot}$	Thermal resistance junction-case, Bottom	0.50	$^\circ\text{C}/\text{W}$
$R_{\theta JA}$	Thermal resistance junction-ambient	60	$^\circ\text{C}/\text{W}$

a. Tested in package DFN-5x6.

➤ **Table 3 Electrical Characteristics** ( $T_{CASE} = 25\text{ }^{\circ}\text{C}$  unless otherwise stated)

Symbol	Parameter	Conditions	Values			Unit
			min.	typ.	max.	
$V_{DSS}$	Drain-source voltage	$V_{GS} = 0V, I_D = 250\mu A$	150	-	-	V
$V_{GS(th)}$	Gate threshold voltage	$V_{DS} = V_{GS}, I_D = 1mA$	0.8	1.1	1.5	V
$R_{DS(on)}$	Drain-source on-resistance	$V_{GS} = 6V, I_D = 20A$	-	5.5	7.2	m $\Omega$
$I_{DSS}$	Drain-source leakage current	$V_{DS} = 120V, V_{GS} = 0V$	-	5	100	$\mu A$
$I_{GSS}$	Gate-to-Source Forward Leakage current	$V_{GS} = +5V, T_J = 25^{\circ}\text{C}$	-	50	800	$\mu A$
	Gate-to-Source Forward Leakage current	$V_{GS} = +5V, T_J = 125^{\circ}\text{C}$	-	600	5500	$\mu A$
	Gate-to-Source Reverse Leakage current	$V_{GS} = -4V, T_J = 25^{\circ}\text{C}$	-	35	1330	$\mu A$
$C_{ISS}$	Input capacitance	$V_{DS} = 75V, V_{GS} = 0V$	-	785	-	pF
$C_{OSS}$	Output capacitance		-	380	-	
$C_{RSS}$	Reverse transfer capacitance		-	13.6	-	
$Q_G$	Gate charge	$V_{DS} = 75V, V_{GS} = 5V, I_D = 20A$	-	9.2	-	nC
$Q_{GS}$	Gate-source charge	$V_{DS} = 75V, I_D = 20A$	-	3.3	-	
$Q_{GD}$	Gate-drain charge		-	1.9	-	
$Q_{OSS}$	Output charge		$V_{DS} = 75V, V_{GS} = 0V$	-	48.8	
$Q_{RR}$	Source-Drain Recovery Charge	-	-	0	-	

### 2. Typical Characteristic Curves

Fig 1. On-Region Characteristics

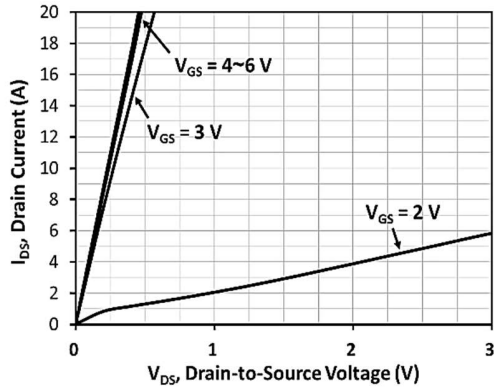

Fig 2. On-Resistance vs Drain Current and Temperature

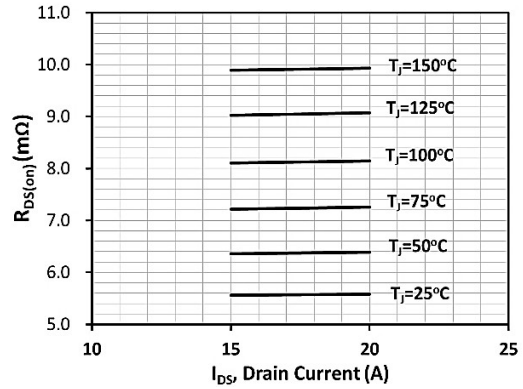

Fig 3. On-Resistance with Drain Current

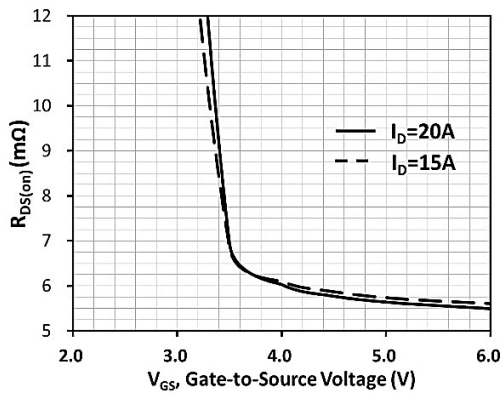

Fig 4. On-Resistance Variation with Temperature

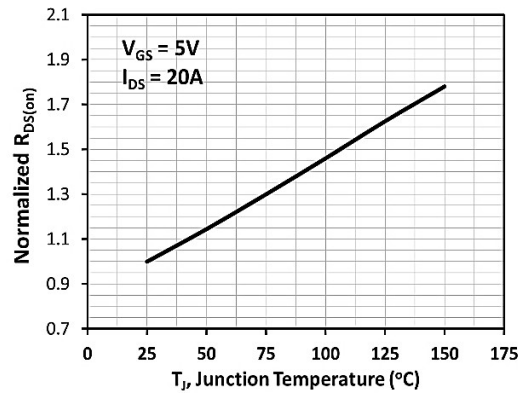

Fig 5. Threshold Voltage with Temperature

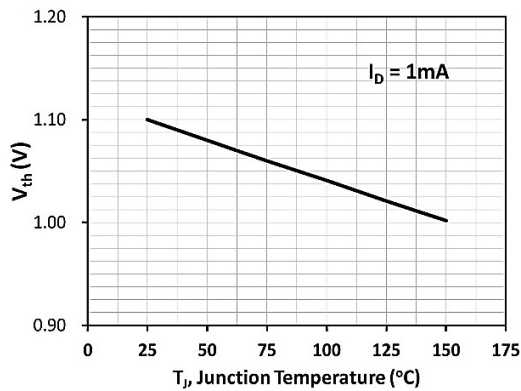

Fig 6. Capacitance Characteristics

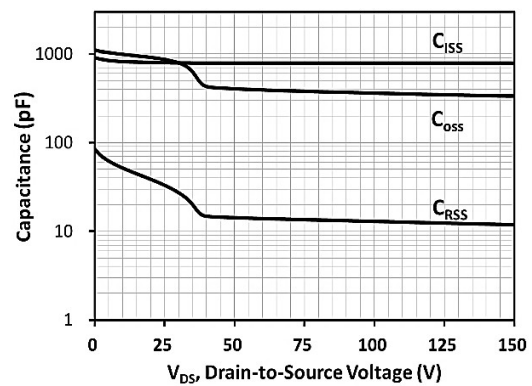

Fig 7. Gate Charge Characteristics, Qg

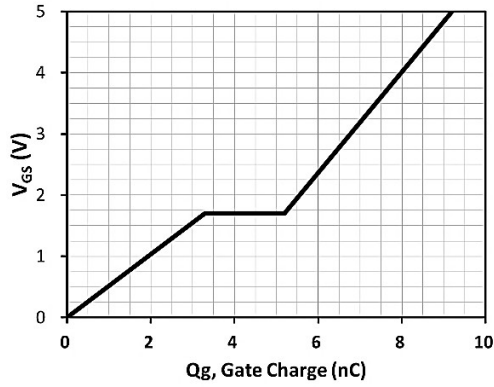

Fig 8. Capacitance Characteristics, Qoss

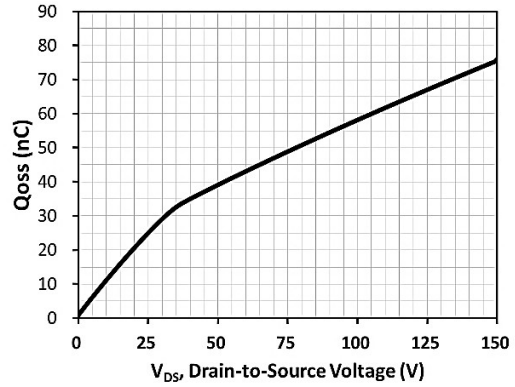
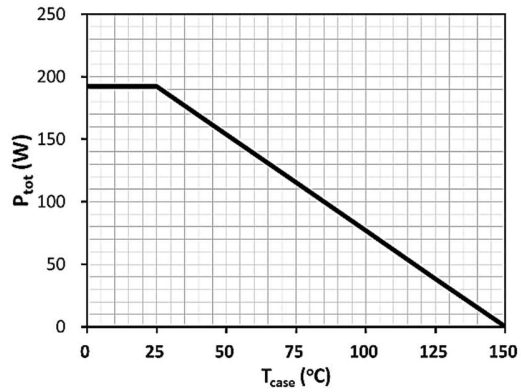
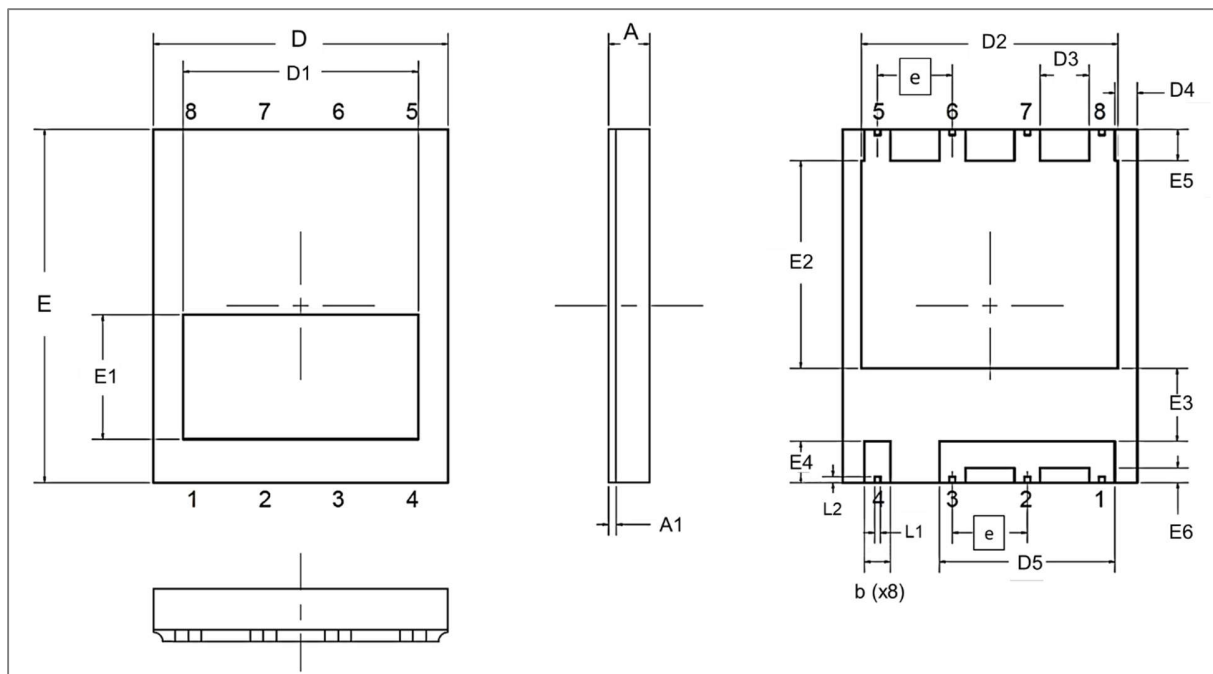

Fig 9. Power Dissipation Derating, Ptot



### 3. Package Outline Dimensions



➤ Table 4 Dimension of GR-DFN-5x6-8L

SYMBOL	DIMENSION (IN MM)			SYMBOL	DIMENSION (IN MM)		
	MIN.	NOM.	MAX.		MIN.	NOM.	MAX.
A	---	---	0.70	D5	2.88	2.98	3.08
A1	0.13			E1	2.112 REF		
A2	0.42	0.45	0.48	E2	3.43	3.53	3.63
D	4.90	5.00	5.10	E3	1.14	1.24	1.34
E	2.90	6.00	3.10	E4	0.60	0.70	0.80
e	1.270 BSC			E5	0.43	0.53	0.63
b	0.34	0.44	0.54	E6	0.15	0.25	0.35
D1	3.994 REF			L1	0.05	0.10	0.20
D2	4.25	4.35	4.45	L2	0.05	0.10	0.20
D3	0.73	0.83	0.93				
D4	0.275	0.375	0.475				

## 4. Recommended PCB footprint

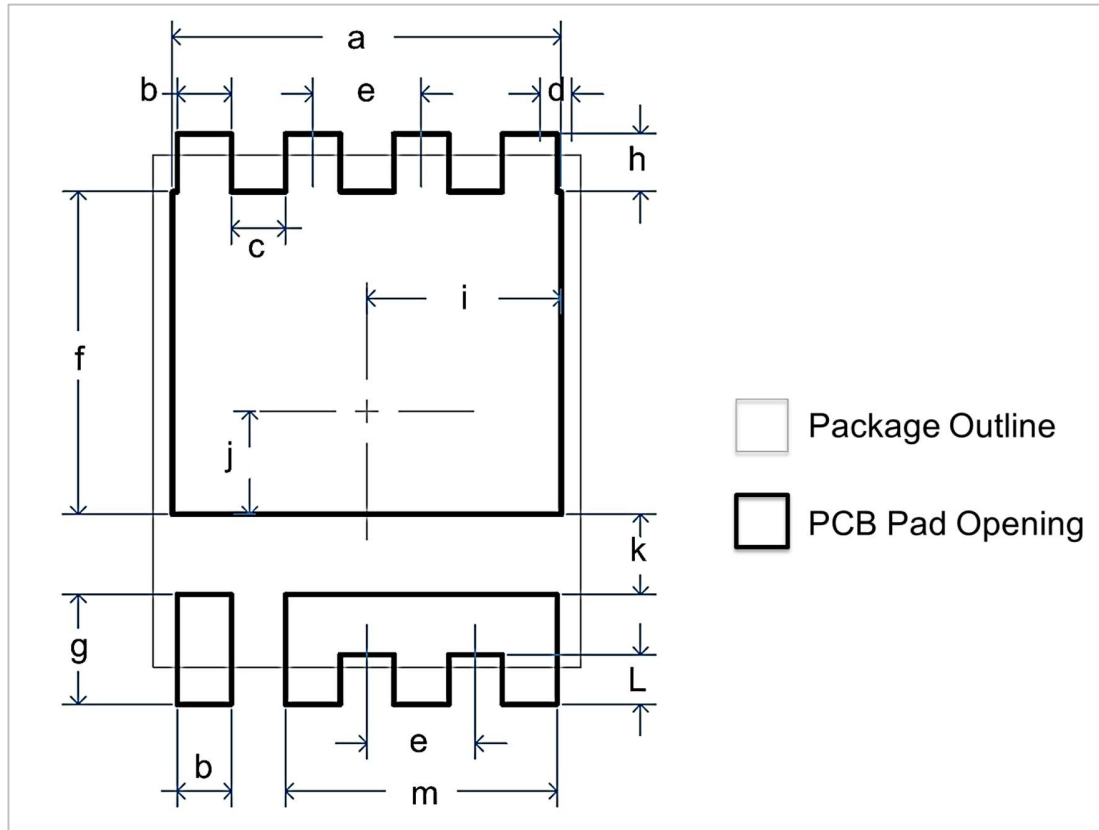

➤ Table 5 PCB Footprint Dimension

SYMBOL	DIMENSION	SYMBOL	DIMENSION
<b>a</b>	4.550	<b>h</b>	0.680
<b>b</b>	0.640	<b>i</b>	2.275
<b>c</b>	0.630	<b>j</b>	1.210
<b>d</b>	0.375	<b>k</b>	0.940
<b>e</b>	1.270	<b>L</b>	0.580
<b>f</b>	3.780	<b>m</b>	3.180
<b>g</b>	1.280	-	-

Notes:

(1) All dimensions are in mm.

(2) Drawing is not to Scale.

### 5. Tape & Reel Information

13" Reel, Carrier Tape W=12mm

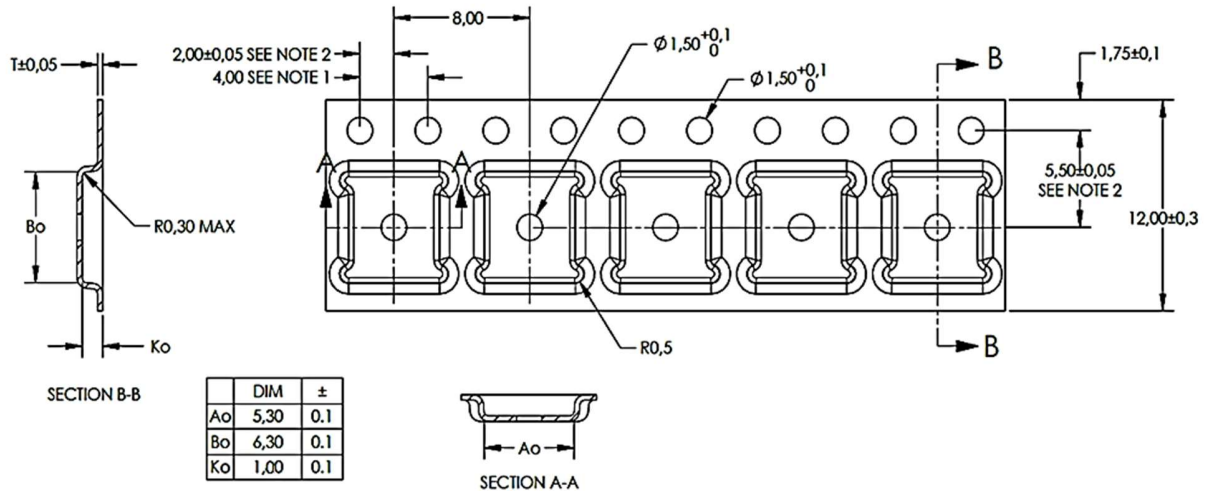

Unit: mm

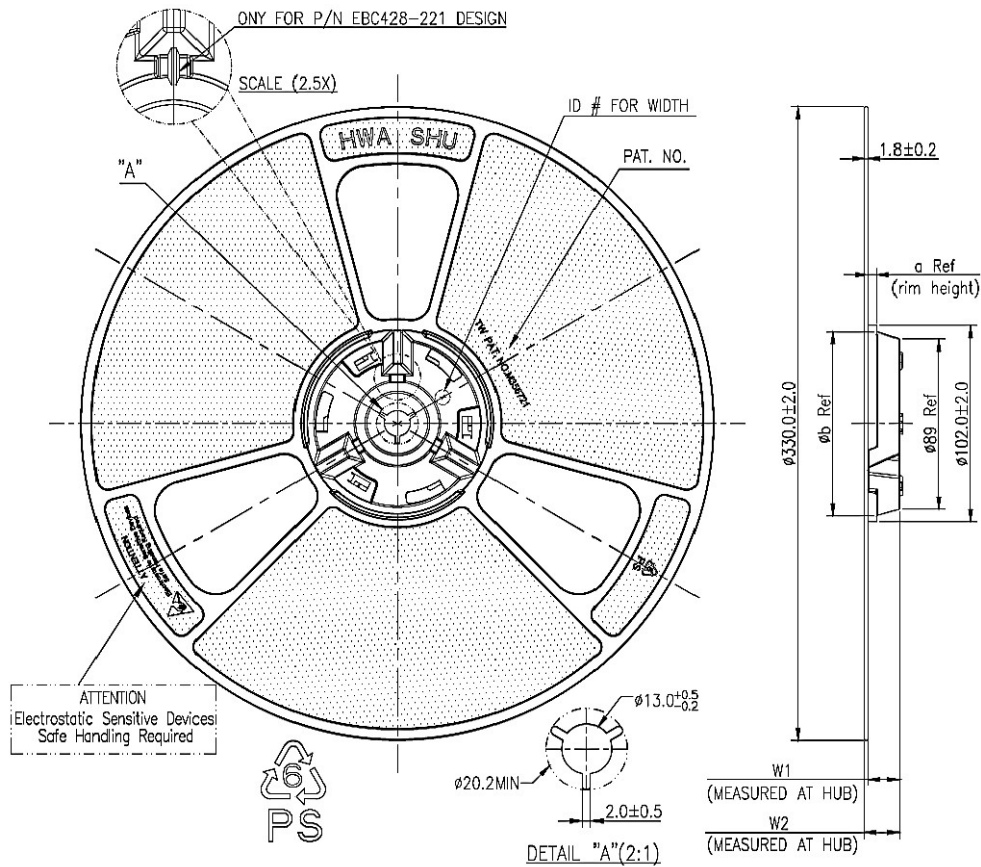

## 6. Change Log

Version	Date	Description
0.1	March 28, 2025	Initial version
0.2	October 22, 2025	Revised electrical characteristic curves.

- **Note:** GaNrich semiconductor reserves the right to revise products and/or specifications without notice.