

GR-65P240AM: DFN 8x8 Cascode GaN HEMT

Description

GR-65P240AM is a normally-off GaN High electron mobility transistor (HEMT) device using the cascode configuration, which provides high breakdown voltage, high current and high operating speed which is suitable for high power applications.

Key Specifications

Part Number	GR-65P240AM
V_{DSS}	650V
$V_{(TR)DSS}$	800V
$R_{DS(ON)}$, typ.	235mΩ
Q_G , typ.	5.9nC
Package	DFN 8 x 8 mm

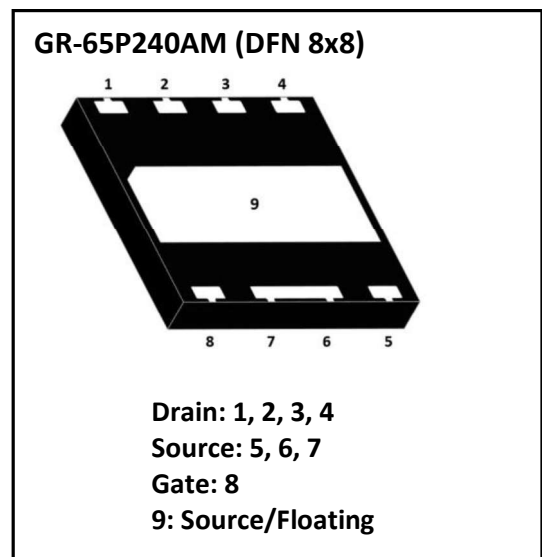

Features

- Gate drive voltage compatibility (-20V to +20V)
- High operating frequency
- Low Q_{rr}

Applications

- Switch Mode Power Supplies (SMPS)
- AC-DC/DC-DC Converters: Boost, Buck, QR Flyback, ACF, AHB, LLC, Half/Full Bridge Application
- Motor Drives, Lighting, Server

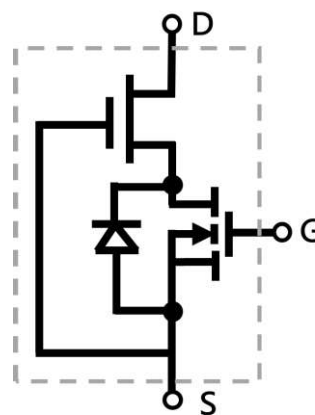

Cascode Device Structure