

GR-65P050NT: TO-247-4L Cascode GaN HEMT

Description

GR-65P050NT is a normally-off GaN High electron mobility transistor (HEMT) device using the cascode configuration, which provides high breakdown voltage, high current and high operating speed which is suitable for high power applications.

Key Specifications

Part Number	GR-65P050NT
V _{DSS} , min.	650V
R _{DS(ON)} , typ.	47mΩ
Package	TO-247-4L

Features

- Gate drive voltage compatibility (-20V to +20V)
- High operating frequency
- Pin to Pin with CoolMOS/SJ and SiC MOSFET
- Low Q_{rr}

Applications

- Switch Mode Power Supplies (SMPS)
- AC-DC/ DC-DC Converters
- Motor Drives

GR-65P050NT (TO-247-4L)

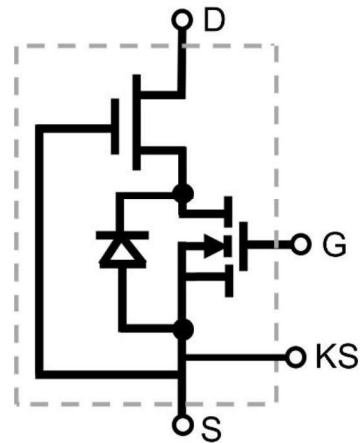

Cascode Device Structure