

### GR-10E001DJ: E-mode GaN Power Transistor

#### Description

GR-10E001DJ is an enhancement mode GaN on Silicon power transistor. 10E001DJ provides high current and high operating speed which is suitable for DC to DC power supply applications.

#### Key Specifications

Part Number	GR-10E001DJ
V <sub>DSS</sub> , min.	100V
I <sub>DS</sub> , Pulse (25°C, TPULSE = 300 μs)	307A
R <sub>DS(ON)</sub> , typ. @V <sub>gs</sub> =6V	1.2mΩ
Q <sub>G</sub> , typ.	28.5nC

#### Features

- 100 V enhancement mode power transistor
- High operating frequency
- R<sub>DS(on)</sub> = Typ. 1.2 mΩ
- RoHS compliant
- Zero QRR.

#### Applications

- Switch Mode Power Supplies (SMPS)
- DC-DC Converters
- Fast Battery Charging
- Appliance Motor Drives

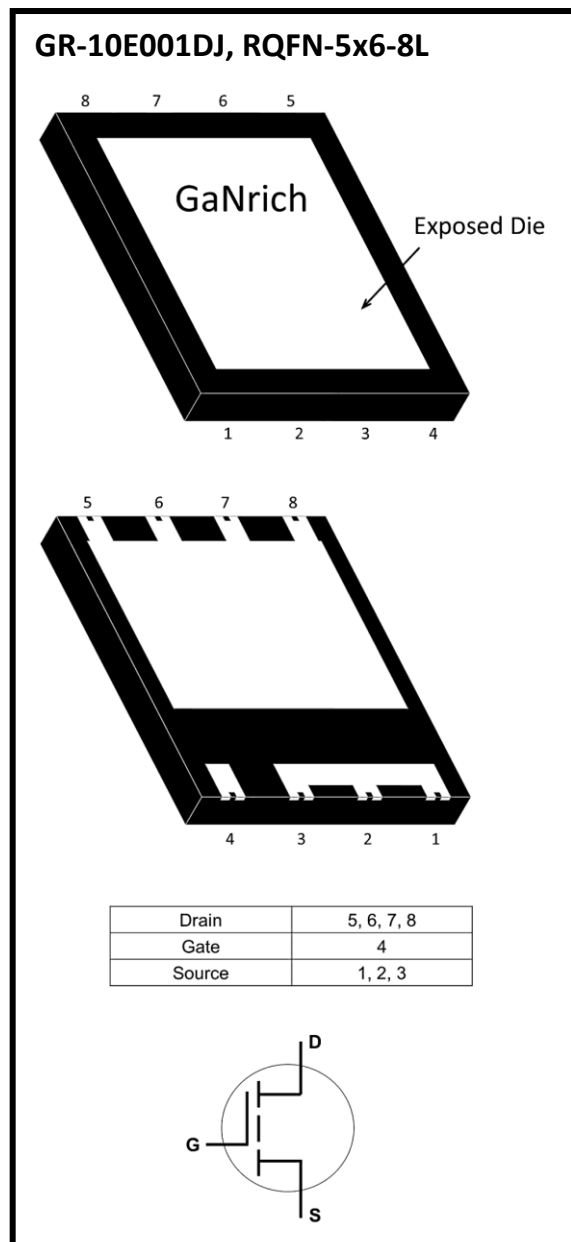

## 1. Electrical Characteristics

➤ **Table 1 Absolute maximum ratings**

Symbol	Parameter	Value	Unit
$V_{DSS}$	Drain-source voltage	100	V
$V_{(TR)DSS}$	Transient drain to source voltage <sup>a</sup>	120	V
$V_{GSS}$	Gate- source voltage	-6V ~ +6V	V
$I_D$	Drain current (continuous) at $T_C = 25^\circ\text{C}$ operation	99	A
	Drain current (continuous) at $T_C = 100^\circ\text{C}$ operation	68	A
$I_{D,pulse}$	Pulsed drain current (pulse width: 300 $\mu\text{s}$ , $V_{gs}=5\text{V}$ ) <sup>b</sup>	307	A
$T_J$	Operating temperature	-40 to +150	$^\circ\text{C}$
$T_S$	Storage temperature	-40 to +150	$^\circ\text{C}$
MSL	Moisture sensitivity level	MSL3	

a. In off-state, spike duty cycle  $D < 0.01$ , spike duration  $< 1\mu\text{s}$

b. Defined by product design and characterization. Value is not tested to full current in production

➤ **Table 2 Thermal Characteristics**

Symbol	Parameter	Value	Unit
$R_{\theta JC\_Top}$	Thermal resistance junction-case, Top	0.50	$^\circ\text{C}/\text{W}$
$R_{\theta JC\_Bot}$	Thermal resistance junction-case, Bottom	0.50	$^\circ\text{C}/\text{W}$
$R_{\theta JA}$	Thermal resistance junction-ambient	60	$^\circ\text{C}/\text{W}$

a. Tested in package DFN-5x6.

➤ **Table 3 Electrical Characteristics** ( $T_{CASE} = 25\text{ }^{\circ}\text{C}$  unless otherwise stated)

Symbol	Parameter	Conditions	Values			Unit
			min.	typ.	max.	
$V_{DSS}$	Drain-source voltage	$V_{GS}=0V, I_D=200\mu A$	100	-	-	V
$V_{GS(th)}$	Gate threshold voltage	$V_G = V_D, I_D=1mA$	0.8	1.1	1.6	V
$R_{DS(on)}$	Drain-source on-resistance	$V_{GS}=6V, I_D=20A$	-	1.2	1.6	m $\Omega$
$I_{DSS}$	Drain-source leakage current	$V_{GS} = 0V, V_{DS} = 80V$	-	10	800	$\mu A$
$I_{GSS}$	Gate-to-Source Forward Leakage current	$V_{GS} = 5V, V_{DS} = 0V$	-	0.19	38.0	mA
	Gate-to-Source Forward Leakage current	$V_{GS} = 5V, V_{DS} = 0V, T_j=125^{\circ}\text{C}$	-	1.5	45.0	mA
	Gate-to-Source Reverse Leakage current	$V_{GS} = -4V, V_{DS} = 0V$	-	0.15	4.5	mA
$C_{ISS}$	Input capacitance	$V_{GS} = 0V, V_{DS} = 50V$	-	3690	-	pF
$C_{OSS}$	Output capacitance		-	1765	-	
$C_{RSS}$	Reverse transfer capacitance		-	85	-	
$Q_G$	Gate charge	$V_{GS}=5V, V_{DS}=50V, I_D = 20A$	-	28.5	-	nC
$Q_{GS}$	Gate-source charge	$V_{DS} = 50V, I_D = 20A$	-	5.4	-	
$Q_{GD}$	Gate-drain charge		-	3.2	-	
$Q_{OSS}$	Output charge	$V_{GS} = 0V, V_{DS} = 50V$	-	80	-	nC
$Q_{RR}$	Source-Drain Recovery Charge	-	-	0	-	nC

### 2. Typical Characteristic Curves

Fig 1. On-Region Characteristics

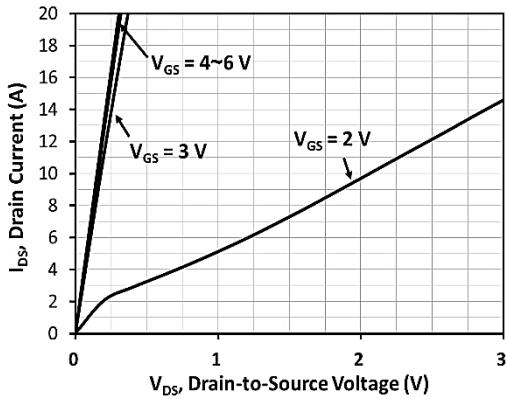

Fig 2. On-Resistance vs Drain Current and Temperature

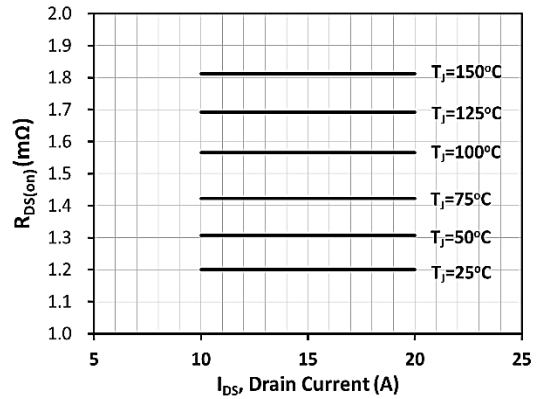

Fig 3. On-Resistance with Drain Current

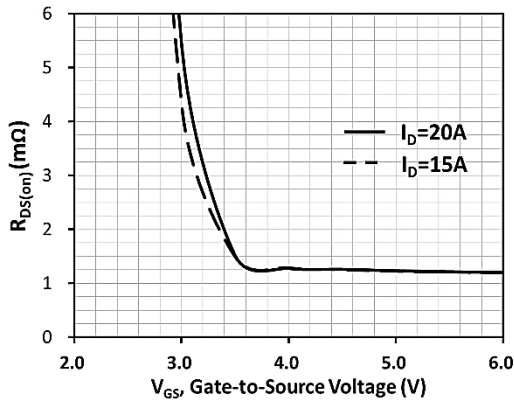

Fig 4. On-Resistance Variation with Temperature

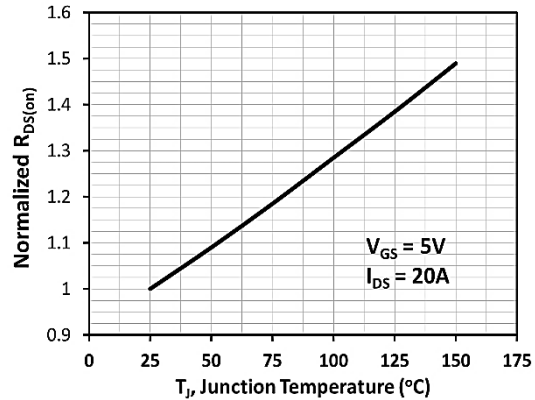

Fig 5. Threshold Voltage with Temperature

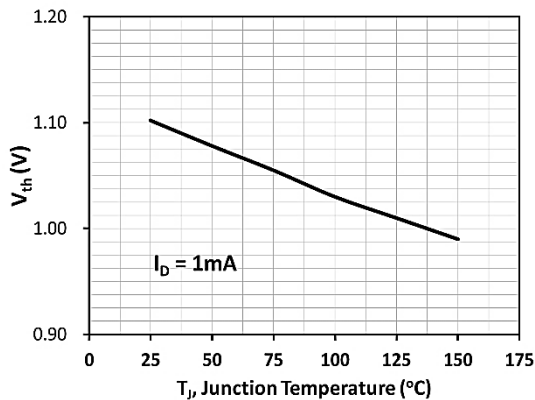

Fig 6. Capacitance Characteristics

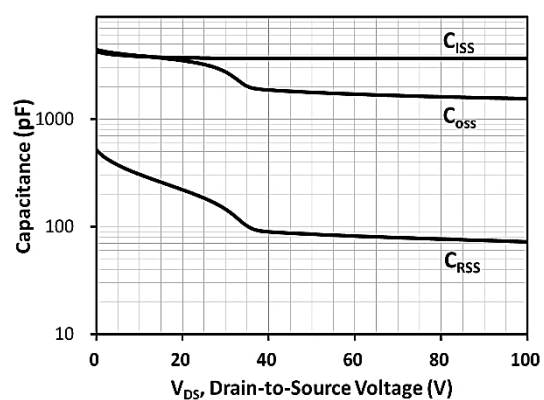

Fig 7. Gate Charge Characteristics, Qg

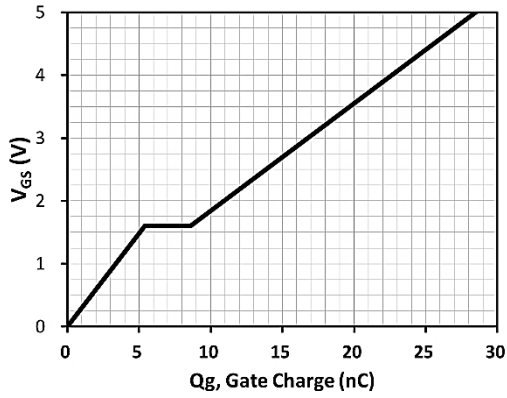
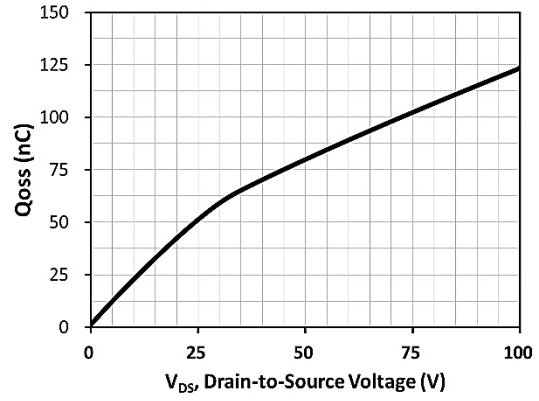
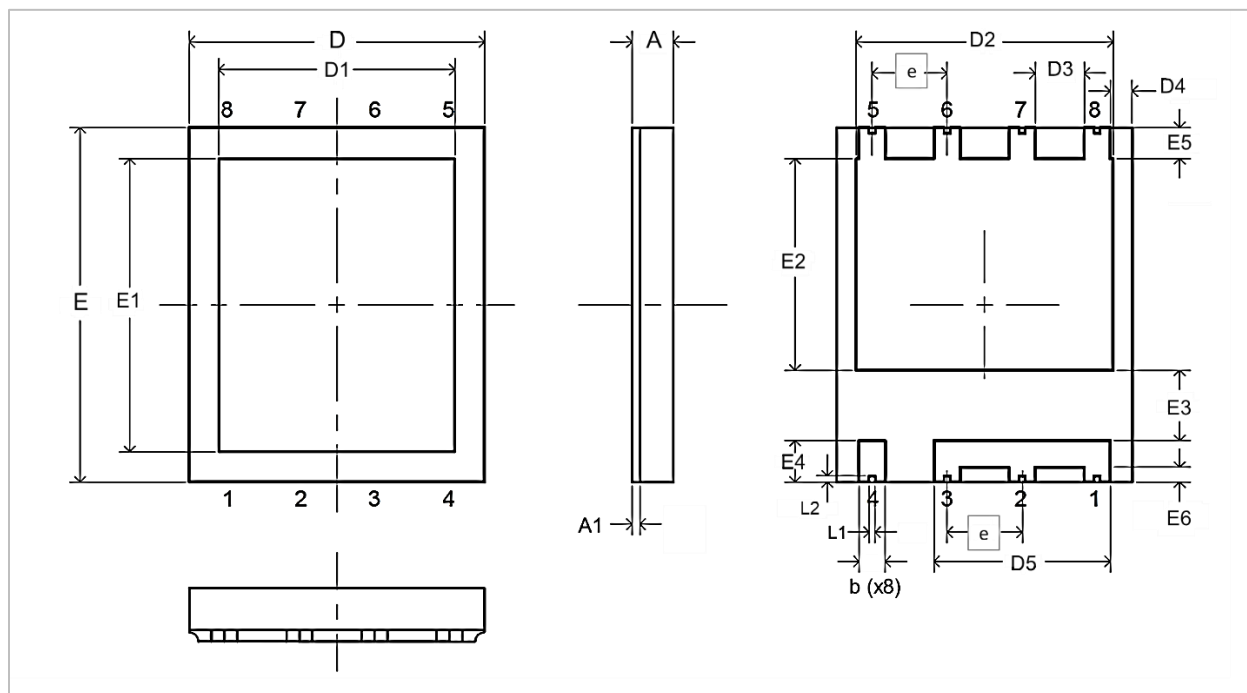

Fig 8. Capacitance Characteristics, Qoss



### 3. Package Outline Dimensions



➤ Table 4 Dimension of GR-RQFN-5x6-8L

SYMBOL	DIMENSION (IN MM)			SYMBOL	DIMENSION (IN MM)		
	MIN.	NOM.	MAX.		MIN.	NOM.	MAX.
A	---	---	0.70	D5	2.88	2.98	3.08
A1	0.13			E1	4.957 REF		
A2	0.42	0.45	0.48	E2	3.48	3.58	3.68
D	4.90	5.00	5.10	E3	1.09	1.19	1.29
E	2.90	6.00	3.10	E4	0.60	0.70	0.80
e	1.27 BSC			E5	0.43	0.53	0.63
b	0.34	0.44	0.54	E6	0.15	0.25	0.35
D1	3.994 REF			L1	0.05	0.10	0.20
D2	4.25	4.35	4.45	L2	0.05	0.10	0.20
D3	0.73	0.83	0.93				
D4	0.275	0.375	0.475				

## 4. Recommended PCB footprint

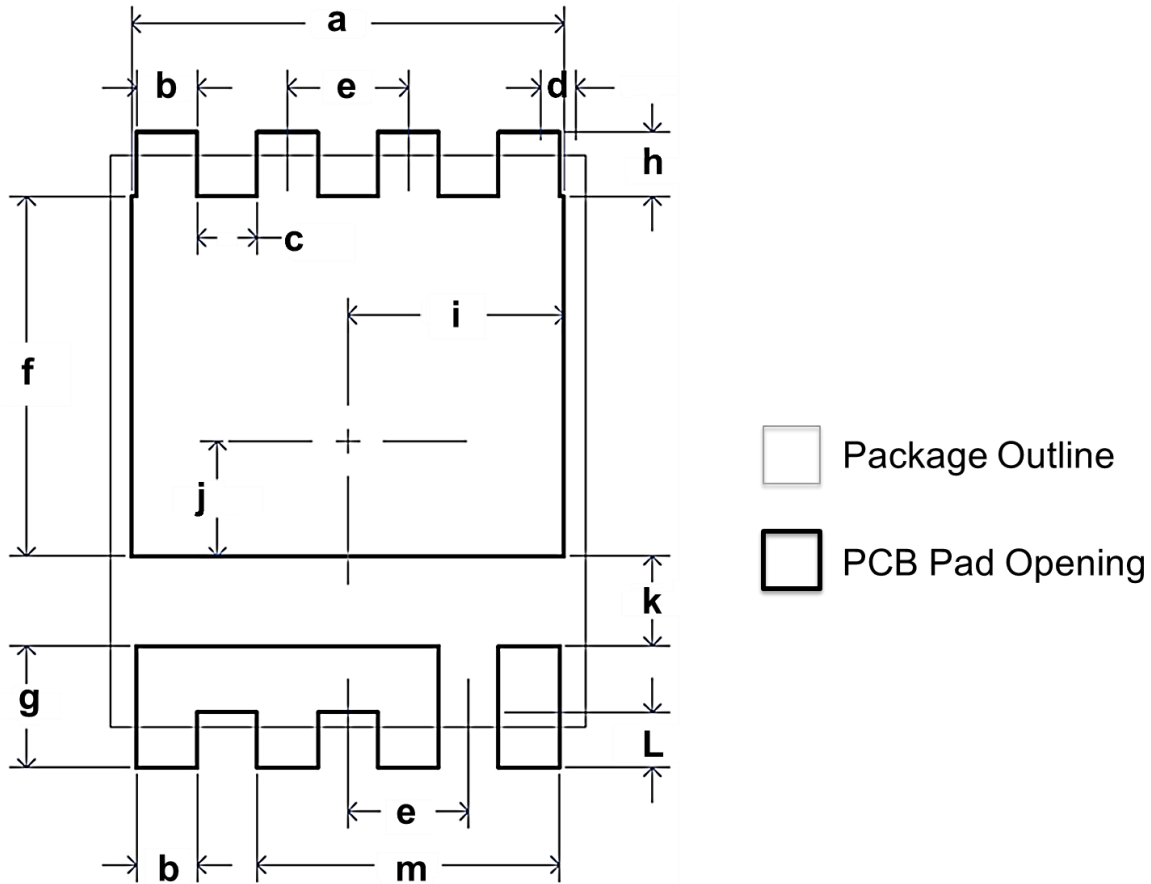

➤ Table 5 PCB Footprint Dimension

SYMBOL	DIMENSION	SYMBOL	DIMENSION
a	4.550	h	0.680
b	0.640	i	2.275
c	0.630	j	1.210
d	0.375	k	0.940
e	1.270	L	0.580
f	3.780	m	3.180
g	1.280	-	-

Notes:

(1) All dimensions are in mm.

(2) Drawing is not to Scale.

### 5. Tape & Reel Information

13" Reel, Carrier Tape W=12mm

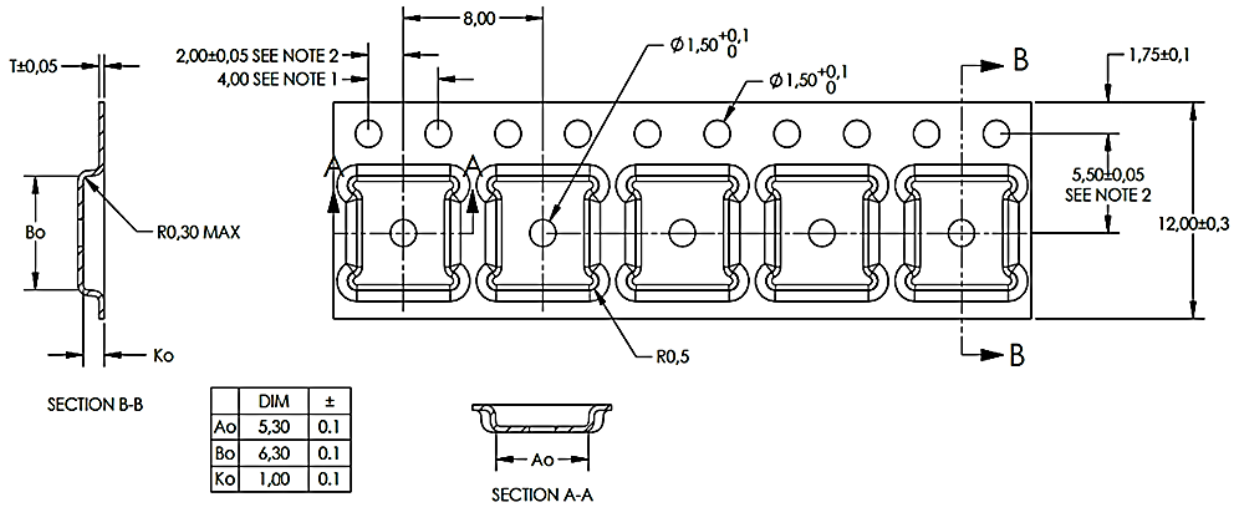

Unit: mm

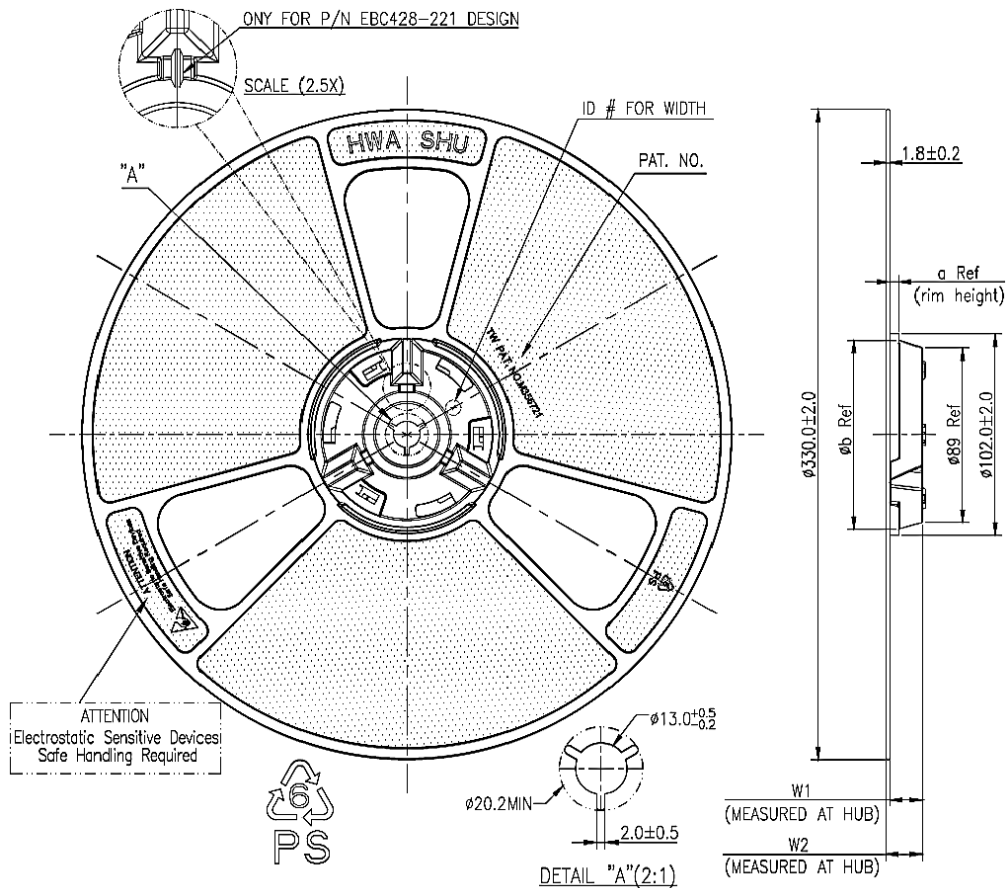

## 6. Change Log

Version	Date	Description
0.1	March 28, 2025	Initial version
0.2	September 26, 2025	Revised version
0.3	April 16, 2026	Electrical characteristics revised

- **Note:** GaNrich semiconductor reserves the right to revise products and/or specifications without notice.